

# 5\*520 / 5\*920 - Drehriegel, Zinkdruckguss

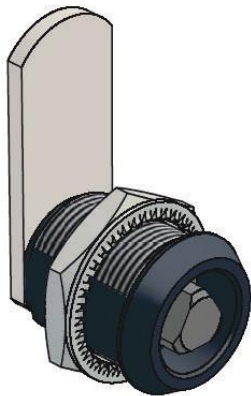

Fixing hole size

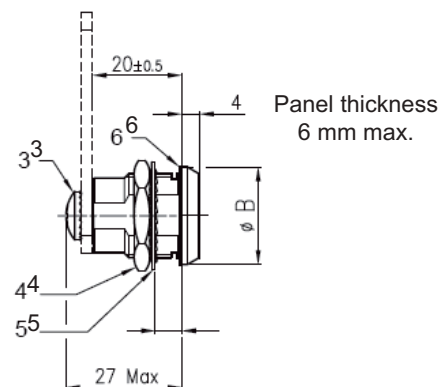
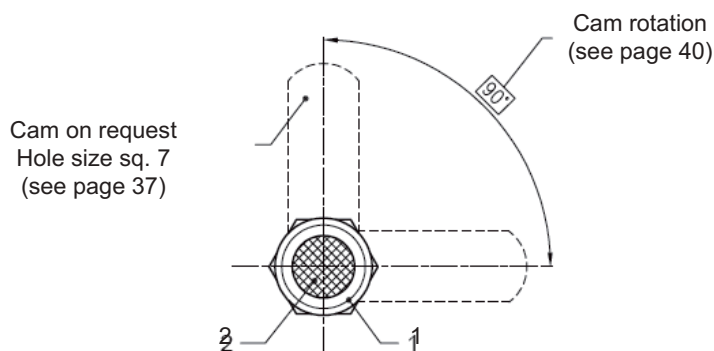
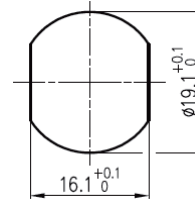

Triangle 6,5 mm

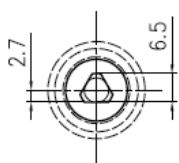

Code: A

Triangle 8 mm

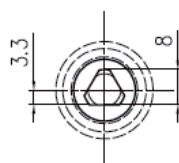

Code: B

Square 7 mm

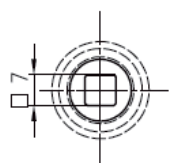

Code: C

Slotted recess

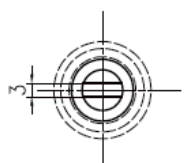

Code: D

Triangle 8 mm

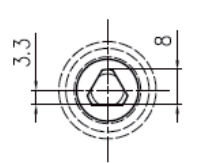

Code: J

P3 pin

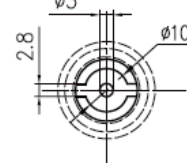

Code: P

Insert \* head style "code" into lock part number.

Lock Part Number (cam excluded)	Housing (Zinc alloy) Dia. - Color	Cylinder (Zinc alloy) Color
5*520NPTSA5TW	ø 22 - Nickel	Nickel
5*520BCTSA5TW	ø 22 - Chrome black	Bright chrome
5*920NPTSA5TW	ø 28 - Nickel	Nickel
5*920BCTSA5TW	ø 28 - Chrome black	Bright chrome

Ref	Part description	Material - Finishing
1	Housing	Zinc alloy - see table
2	Cylinder	Zinc alloy - see table
3	Screw M5	Steel - White zinc Cr6 free
4	Nut M19X1 - Ch. 22	Brass
5	Washer	Steel - White zinc Cr6 free
6	Protection washer	Nylon