

5*313 - Drehriegel, Zinkdruckguss

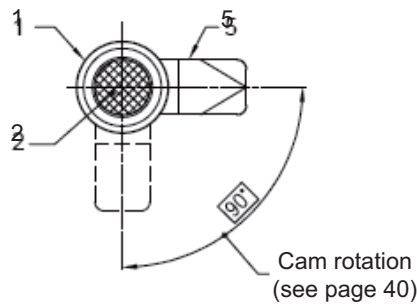

Fixing hole size

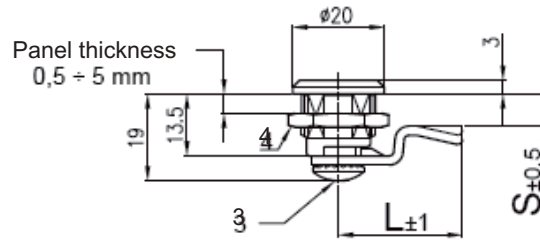
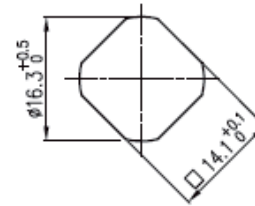

Triangle 6,5 mm

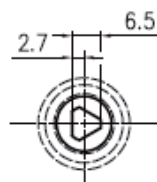

Code: A

Slotted recess

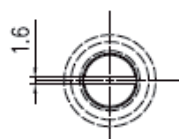

Code: D

Square 6 mm

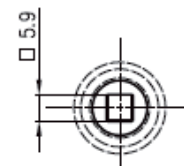

Code: F

Insert * head style "code" into lock part number.

Lock Part Number	L ±1	S ±0,5
5*313CPNRA5T628	27	7
5*313CPNRA5T	24	13,5

Ref	Part description	Material - Finishing
1	Housing	Zinc alloy - Bright chrome
2	Cylinder	Zinc alloy - Bright chrome
3	Screw M5	Steel - White zinc Cr6 free
4	Nut M16X1	Steel - White zinc Cr6 free
5	Cam	FeP02 - White zinc Cr6 free