

5*1196 - einstellbarer Drehriegel, Zinkdruckguss

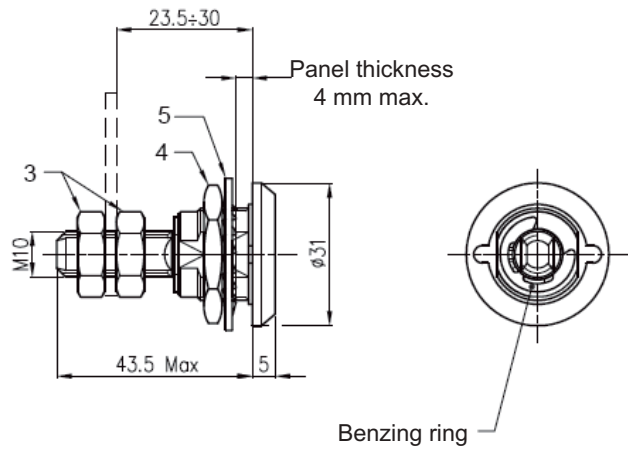

Triangle 8 mm

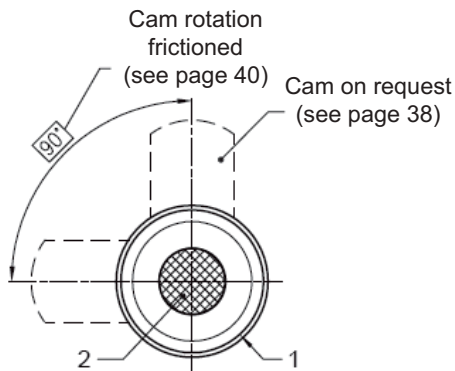
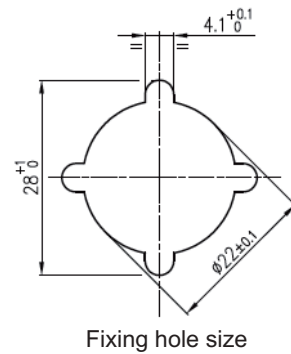
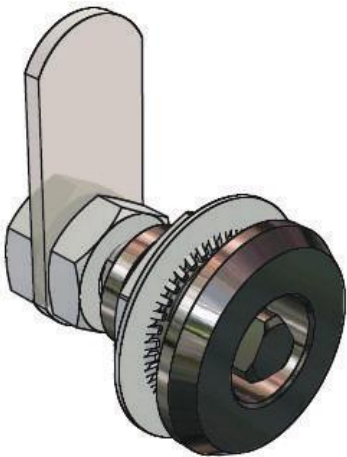
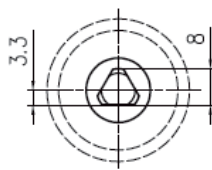

Code: B

Slotted recess

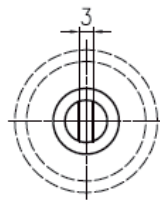

Code: D

P3 pin

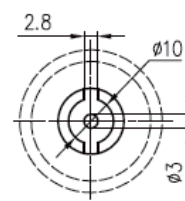

Code: P

Insert * head style "code" into lock part number.

Lock Part Number (cam excluded)
5*1196CPWZJ5TW

Ref	Part description	Material - Finishing
1	Housing	Zinc alloy - Bright chrome
2	Cylinder	Zinc alloy - Bright chrome
3	Nut M10 low (2)	Steel - White zinc Cr6 free
4	Nut M20X1	Brass
5	Washer	Steel - White zinc Cr6 free